



# Thermia WT-T



## Non-corrosive water heaters with TWS coil

**Thermia WT-T** is a water heater with a TWS coil providing highly effective heating of hot tap water. The water heater's non-corrosive, tempered design makes it extra corrosion-proof, with no cathodic protection required in the tank.

The heater's TWS technology\* provides extremely effective heat transfer and enables better water stratification than traditional technology. This means that water heats more quickly, energy usage is reduced, and hot water lasts longer when there are large draughts. Hot water production using hot gas converters means even greater benefits are reaped from the TWS technology.

Thermia WT-T has a socket for the electric heating element and hot water circulation. This is a useful closure device in building solutions as it ensures that the temperature of running hot tap water is correct.

Thermia WT-T is available in 300 and 500 litre sizes and can be cascade-connected if demand is high. In other words, they can be used with heat pumps in family homes and also in larger systems in buildings.

\* TWS = Tap Water Stratification.

**B**

Energy efficiency class for water heater

WT-T 300



WT-T 500



# Technical data WT-T 300 WT-T 500

## Connections

- 1 Connections (2x), DN50 int.
- 2 Circulation, DN25 int.
- 3 Temperature sensor conn. DN15 int.
- 4 Temperature sensor conn. DN15 int (located on the "backside")
- 5 Coil supply, DN25 int.
- 6 Coil return, DN25 int.
- 7 Immersion heater conn. DN50 int.

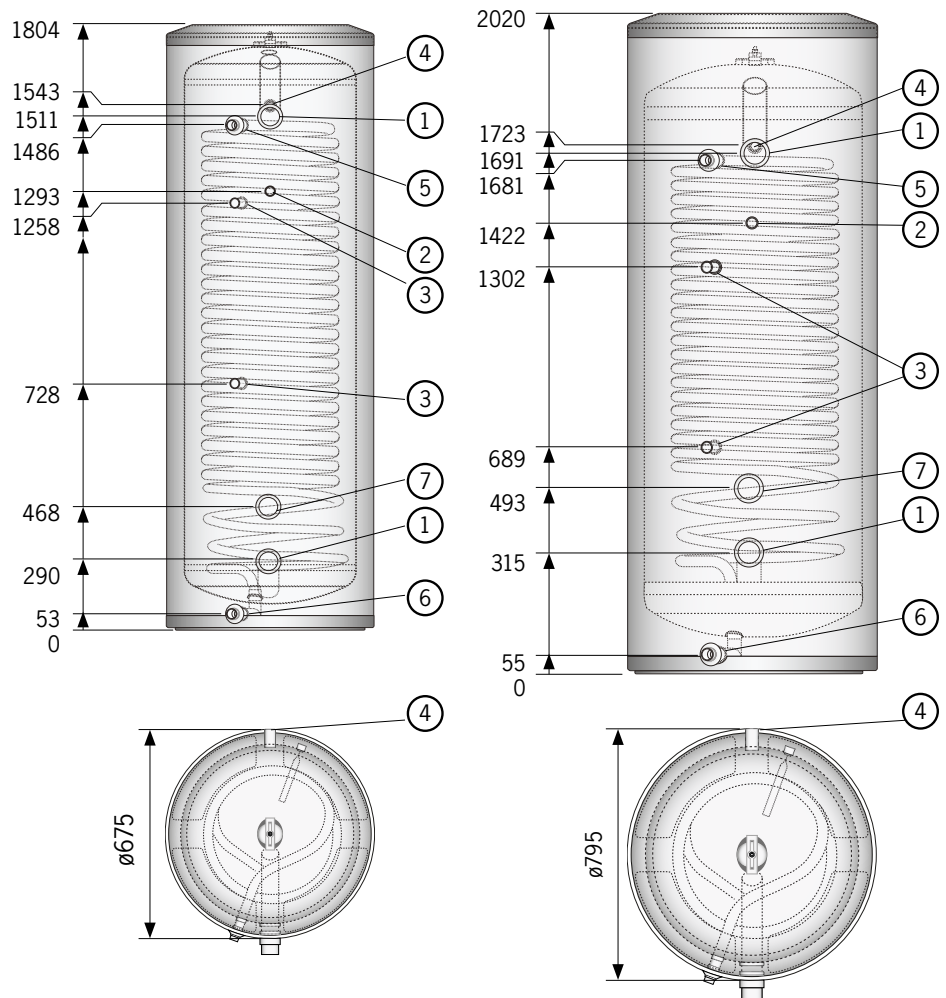

WT-T 300	
Corrosion protection	stainless
Storage volume V (litres)	281,1
Water storage volume, coil (litres)	18
Length, coil (m)	30
Heating surface, coil (m <sup>2</sup> )	2,9
Working pressure (bar)	10
Test pressure (bar)	14,3
Max. pressure, coil (bar)	10
Max. temperature (°C)	100
Immersion heater, max. output (kW)	6
Max. immersion heater length (mm)	460
Standing loss S <sup>1</sup>	65,5
Energy efficiency class	B
Height (mm)	1804
Width (mm)	675
Depth (mm)	675
Weight (kg)	69

1) According to EN 12897:2016

Required ceiling height for tilting: min. 1950 mm

WT-T 500	
Corrosion protection	stainless
Storage volume V (litres)	460,9
Water storage volume, coil (litres)	24
Length, coil (m)	39
Heating surface, coil (m <sup>2</sup> )	3,7
Working pressure (bar)	10
Test pressure (bar)	14,3
Max. pressure, coil (bar)	10
Max. temperature (°C)	100
Immersion heater, max. output (kW)	9
Max. immersion heater length (mm)	570
Standing loss S <sup>1</sup>	79,1
Energy efficiency class	B
Height (mm)	2020
Width (mm)	795
Depth (mm)	795
Weight (kg)	93

1) According to EN 12897:2016

Required ceiling height for tilting: min. 2200 mm